



**Novibra® type EH**

Type EH mountings are designed to achieve effective vibration isolation on engines, operator cabins and other ancillary units.

Typical applications can be found in the following areas:

- Off-road equipment
- Military vehicles
- Transport machinery
- Construction equipment
- Agricultural vehicles
- Industrial mobile machinery

**Max tightening torque**

- EH 4850: 40 Nm
- EH 6463: 80 Nm
- EH 9075: 200 Nm

**Features**

Type EH is designed primarily for mobile applications where high dynamic and shock forces are encountered.

Dynamic vertical movements in both the directions are restricted and excellent horizontal stability is provided.

Stress on brackets are optimized while at the same time obtaining vibration isolation and shock absorption.

The function of EH includes features as:

- Dynamic efficiency in all directions
- Attenuation of structure-borne noise
- Accommodation of misalignment and distortion
- Simple design – easy to install
- Fail-safe installation
- Wide load range, 80 to 450 kg

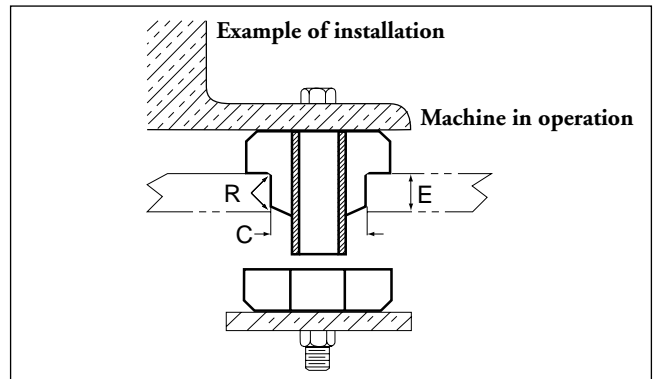
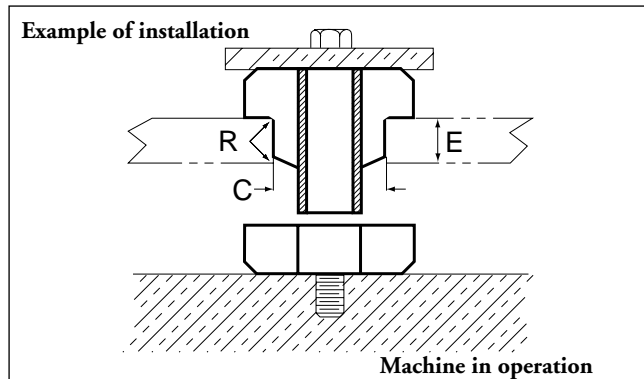
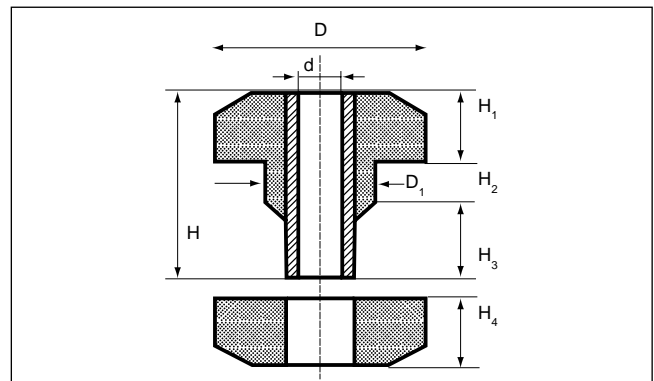

**Table of dimensions for installation**

Type	Dimensions in mm		
	C	E	R
EH 4850	31.0	15.0	1.5
EH 6463	39.0	22.0	2.3
EH 9075	56.5	28.0	3.0

Type	Art.No. 40° IRH	Art.No. 60° IRH	Dimensions in mm								Max load (kg)	
			d	D	D1	H	H1	H2	H3	H4	40° IRH	60° IRH
EH 4850	1860570	1860560	13.0	50	32	50	20	10	20	20	80	130
EH 6463	1860550	1860540	17.0	64	40	62	23	14	25	23	120	260
EH 9075	1860530	1860520	23.0	89	58	73	25	19	29	25	260	450

Note: The natural frequencies and degrees of isolation are based on dynamic characteristics of the mountings.

Load per mounting (kg)

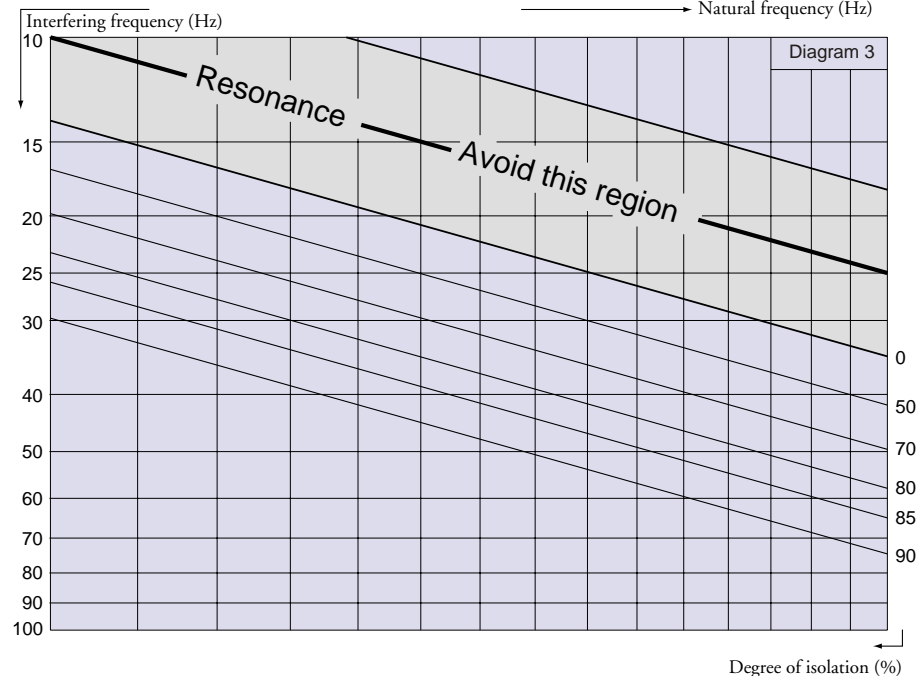
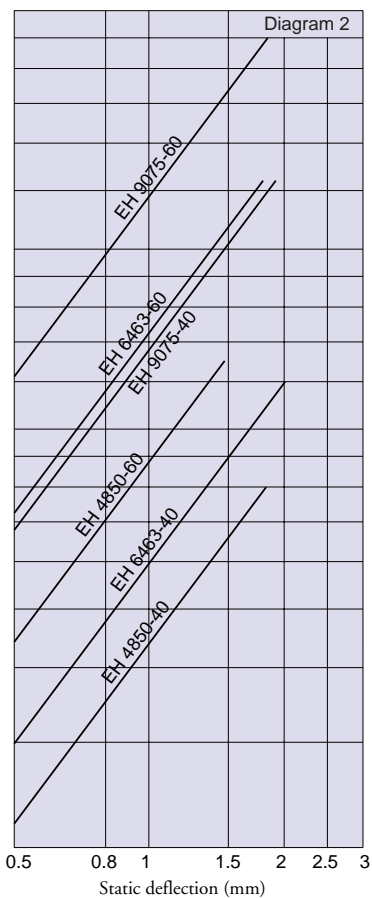
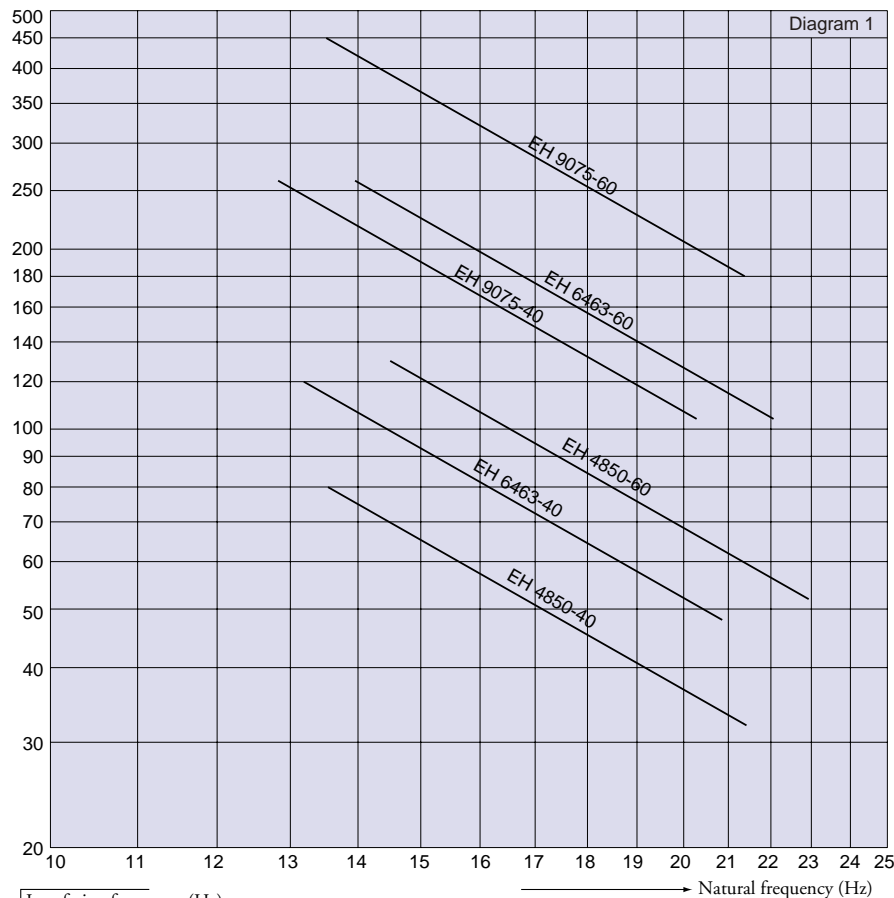

To select correct mounting, following data are needed:  
 1) Load per mounting (kg)  
 2) Interfering frequency (Hz) (Hz = rpm / 60)  
 Select correct load line in diagram 1 and correct interference line in diagram 3. The load line intersects with required type of mounting. Connect this intersection point vertically down to the interference line in diagram 3. Here, on the sloping curve, the isolation degree is indicated. For static deflection, see diagram 2.

